

Optimizing Performance: Spherical Roller Bearings with Steel Cage Technology

1 Introduction

[Spherical Roller Bearings](#) with Steel Cage Technology have emerged as a cornerstone in enhancing the performance of industrial machinery. The marriage of Spherical Roller Bearings with steel cage design represents a significant advancement in bearing technology, offering unparalleled durability, reliability, and efficiency. In today's competitive industrial landscape, the quest for optimizing performance has become paramount, driving engineers and manufacturers to seek innovative solutions to maximize productivity and operational effectiveness.

Exploring Leading Brands of Spherical Roller Bearings with Steel Cage

Spherical roller bearings with steel cage technology are pivotal components in various industrial applications, offering exceptional durability, reliability, and performance.

1. SKF (Svenska Kullagerfabriken AB):

SKF is a global leader in the manufacture of bearings, including spherical roller bearings with steel cages. Their bearings are engineered to withstand heavy loads, high speeds, and harsh operating conditions, making them ideal for diverse applications in industries such as automotive, mining, and construction. SKF's extensive research and development efforts ensure continuous improvements in bearing design and performance, setting the standard for reliability and efficiency.

2. FAG (Fischer Aktien-Gesellschaft):

FAG, a subsidiary of the Schaeffler Group, is renowned for its high-quality spherical roller bearings with steel cages. Leveraging advanced engineering and manufacturing technologies, FAG bearings are known for their precision, durability, and superior performance. With a comprehensive product portfolio and a strong focus on innovation, FAG continues to meet the evolving needs of industries worldwide, delivering solutions that optimize performance and minimize downtime.

3. NSK (Nippon Seiki Kabushiki-gaisha):

NSK is a leading manufacturer of spherical roller bearings with steel cages, offering a wide range of products tailored to meet the demands of various industries. NSK's bearings are characterized by their robust construction, exceptional load-carrying capacity, and long service life. Through continuous investment in research and development, NSK remains at the forefront of bearing technology, providing customers with innovative solutions that enhance productivity and efficiency.

4. Timken Company:

The Timken Company is a trusted name in the field of bearings, including spherical roller bearings with steel cages. Timken's bearings are engineered to deliver superior performance in demanding applications, thanks to their innovative design, high-quality materials, and precision manufacturing processes. With a rich history of innovation spanning over a century, Timken continues to push the boundaries of bearing technology, delivering solutions that drive efficiency and reliability for its customers.

5. NTN Corporation:

NTN Corporation is a leading manufacturer of spherical roller bearings with steel cages, offering a comprehensive range of products designed to meet the needs of diverse industries worldwide. NTN's bearings are known for their exceptional quality, reliability, and performance, making them the preferred choice for critical applications in automotive, aerospace, and industrial machinery. With a focus on innovation and customer satisfaction, NTN remains committed to delivering cutting-edge bearing solutions that optimize performance and minimize total cost of ownership.

6. Schaeffler Group:

The Schaeffler Group, comprising the brands INA and FAG, is a global leader in bearing technology, including spherical roller bearings with steel cages. Schaeffler's bearings are synonymous with precision engineering, superior quality, and unmatched reliability. With a strong emphasis on research and development, the Schaeffler Group continues to drive innovation in bearing design and manufacturing, ensuring that its products meet the highest standards of performance and durability.

Brand	Key Features	Advantages	Applications
SKF	- Exceptional durability- High load-carrying capacity- Advanced engineering and design	- Renowned global brand- Extensive research and development- Superior reliability	- Automotive- Mining- Construction
FAG	- Precision engineering- High-quality materials- Superior performance	- Strong focus on innovation- Comprehensive product portfolio- Precision manufacturing processes	- Automotive- Aerospace- Industrial machinery
NSK	- Robust construction- Long service life-	- Leading manufacturer- Continuous investment in	- Automotive- Aerospace- Industrial machinery

	Exceptional load-carrying capacity	R&D- Innovative solutions	
Timken	- Innovative design- High-quality materials- Precision manufacturing	- Rich history of innovation- Superior performance- Trusted name in the industry	- Automotive- Mining- Agriculture
NTN	- Exceptional quality- Reliability- High performance	- Comprehensive product range- Customer satisfaction- Focus on innovation	- Aerospace- Industrial machinery- Automotive
Schaeffler Group	- Precision engineering- Unmatched reliability- Superior quality	- Global leader in bearing technology- Precision manufacturing- Commitment to innovation	- Automotive- Aerospace- Wind turbines

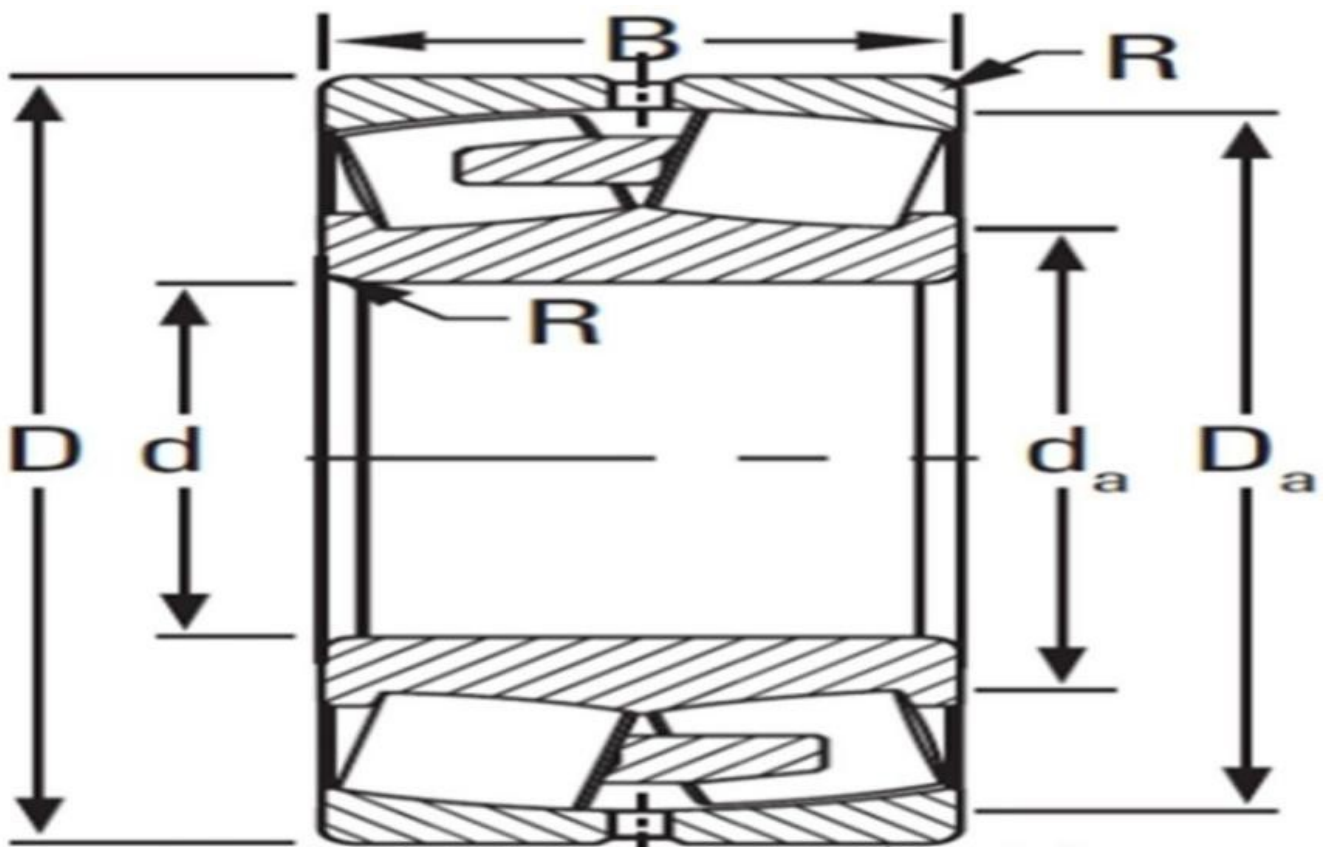

Spherical Roller Bearings/Steel Cage

2 Understanding Spherical Roller Bearings

Spherical Roller Bearings are precision-engineered components designed to facilitate rotational motion while accommodating radial and axial loads. Unlike traditional ball bearings, which have point contact, Spherical Roller Bearings feature a barrel-shaped rolling element, allowing for increased contact area and improved load distribution. These bearings find widespread applications across various industries, including automotive, aerospace, mining, and manufacturing, where heavy-duty machinery operates under demanding conditions.

The role of Spherical Roller Bearings in industrial machinery cannot be overstated. These bearings serve as critical components in rotating shafts, gearboxes, and other mechanical systems, providing support, reducing friction, and ensuring smooth operation. With their ability to handle both radial and axial loads, Spherical Roller Bearings offer versatility and reliability, making them suitable for diverse applications ranging from conveyor systems to wind turbines.

One of the key advantages of Spherical Roller Bearings lies in their ability to accommodate misalignment. Due to their spherical design, these bearings can tolerate shaft misalignment to a certain degree, reducing the risk of premature wear and failure. When combined with a steel cage, Spherical Roller Bearings exhibit enhanced durability and stability, further optimizing performance and extending service life. The steel cage serves as a robust framework, guiding the movement of the rolling elements and maintaining proper spacing, even under heavy loads and high speeds.

In summary, understanding the principles and advantages of Spherical Roller Bearings, particularly when equipped with a steel cage, is crucial for optimizing performance in industrial machinery. By harnessing the capabilities of these advanced bearings, engineers and manufacturers can achieve higher levels of efficiency, reliability, and productivity in their operations.

3 Exploring Steel Cage Technology

Introduction to Steel Cage Technology in Spherical Roller Bearings

Spherical Roller Bearings with Steel Cage Technology represent a significant advancement in bearing design, offering unmatched durability, strength, and performance. The steel cage serves as a critical component within the bearing, providing structural support and guiding the movement of the rolling elements. Unlike traditional cage materials such as brass or polyamide, steel offers superior mechanical properties, including high tensile strength and resistance to wear and deformation. This makes steel cage bearings ideal for applications where reliability and longevity are paramount.

Benefits of Steel Cage Design

The adoption of steel cage technology in Spherical Roller Bearings brings forth a myriad of benefits. Firstly, steel cages exhibit exceptional durability, capable of withstanding heavy loads and harsh operating conditions without compromising performance. This inherent strength contributes to extended bearing life and reduced maintenance requirements, translating to cost savings for end-users.

Moreover, steel cages offer enhanced strength and rigidity compared to alternative materials. This allows for greater precision in bearing operation, minimizing the risk of cage deformation or failure under load. As a result, Spherical Roller Bearings with steel cages deliver smoother operation, reduced vibration, and improved overall performance in industrial machinery and equipment.

Another notable advantage of steel cage design is its thermal stability. Steel possesses excellent heat resistance, making it well-suited for applications where temperature fluctuations are common. Unlike organic cage materials, which may degrade or soften at elevated temperatures, steel maintains its structural integrity, ensuring reliable performance even in extreme environments.

Comparison of Steel Cage vs. Other Cage Materials

When compared to alternative cage materials such as brass or polyamide, steel offers distinct advantages in terms of durability, strength, and thermal stability. While brass cages may provide good corrosion resistance, they are often less robust and prone to deformation under heavy loads. Polyamide cages, on the other hand, offer lightweight and cost-effective solutions but may lack the strength and longevity of steel.

In summary, the adoption of Steel Cage Technology in Spherical Roller Bearings brings forth a host of benefits, including superior durability, strength, and thermal stability. By harnessing the advantages of steel cages, engineers and manufacturers can optimize the performance and reliability of their machinery, ensuring smooth operation and extended service life.



Spherical Roller Bearings/Steel Cage

4 Applications of Spherical Roller Bearings with Steel Cage

<p>Automotive Applications</p>	<p>In the automotive industry, Spherical Roller Bearings with Steel Cage play a crucial role in various vehicle components, ensuring optimal performance and reliability. These bearings are commonly found in wheel hubs, where they support the vehicle's weight and facilitate smooth rotation. The steel cage design enhances durability, making it well-suited for the demanding conditions encountered on the road. Additionally, Spherical Roller Bearings with Steel Cage are utilized in drivetrain components such as transmission systems and propeller shafts, where they provide reliable operation under high loads and speeds. By incorporating steel cage technology, automotive manufacturers can optimize performance and enhance the driving experience for consumers.</p>
--------------------------------	---

<p>Industrial Applications</p>	<p>In industrial settings, Spherical Roller Bearings with Steel Cage are utilized in a wide range of heavy machinery and equipment. From manufacturing plants to mining operations, these bearings play a critical role in ensuring the smooth and efficient operation of industrial processes. In conveyor systems, for example, Spherical Roller Bearings with Steel Cage provide reliable support for rollers and pulleys, facilitating the movement of materials throughout the facility. Moreover, in equipment such as crushers, screens, and pumps, these bearings withstand heavy loads and harsh operating conditions, delivering consistent performance and minimizing downtime. With their superior durability and strength, Spherical Roller Bearings with Steel Cage are indispensable components in the industrial landscape, contributing to increased productivity and operational efficiency.</p>
<p>Aerospace Applications</p>	<p>In the aerospace industry, where precision and reliability are paramount, Spherical Roller Bearings with Steel Cage are utilized in critical aircraft components. These bearings are commonly employed in aircraft engines, where they support rotating shafts and ensure smooth operation at high speeds and temperatures. The steel cage design provides exceptional strength and stability, allowing Spherical Roller Bearings to withstand the extreme conditions encountered during flight. Additionally, Spherical Roller Bearings with Steel Cage are used in landing gear assemblies, control systems, and other aircraft components, where they contribute to the safety and performance of the aircraft. By incorporating steel cage technology, aerospace manufacturers can achieve the stringent performance requirements of the industry and ensure the safety of air travel.</p>

In summary, Spherical Roller Bearings with Steel Cage find diverse applications across automotive, industrial, and aerospace sectors, providing reliable performance and durability in demanding environments. By leveraging the benefits of steel cage technology, industries can optimize performance, enhance reliability, and achieve greater efficiency in their operations.

5 Future Trends and Innovations

Emerging Trends in Steel Cage Technology for Spherical Roller Bearings

In recent years, the field of steel cage technology for spherical roller bearings has witnessed notable advancements and innovations, paving the way for future developments that promise to further optimize performance and efficiency in various industrial applications.

Advancements in Steel Cage Design	One of the key trends in steel cage technology is the continuous evolution of cage design to enhance bearing performance under demanding operating conditions. Manufacturers are exploring innovative cage geometries and materials to improve load distribution, reduce friction, and minimize wear, ultimately extending the service life of spherical roller bearings.
Integration of Advanced Materials	Another emerging trend is the integration of advanced materials in steel cage construction. By incorporating high-performance alloys and composites, engineers can achieve superior strength, durability, and temperature resistance, enabling spherical roller bearings to withstand extreme environments encountered in industries such as mining, construction, and aerospace.
Enhanced Lubrication Systems	Future innovations in steel cage technology are also expected to focus on optimizing lubrication systems within spherical roller bearings. Advanced lubricants and delivery mechanisms will be employed to ensure proper lubrication under all operating conditions, reducing friction, heat generation, and wear, while maximizing bearing performance and reliability.
Predictions for Future Developments	Looking ahead, industry experts predict that steel cage technology will continue to evolve rapidly to meet the evolving demands of various sectors. Future developments may include the integration of smart sensors for condition monitoring, the application of nanotechnology for surface treatments, and

	the adoption of additive manufacturing techniques for customized cage designs.
Importance of Research and Development	As the demand for high-performance spherical roller bearings with steel cage technology grows, the importance of ongoing research and development cannot be overstated. Collaborative efforts between manufacturers, researchers, and end-users will drive innovation, leading to the creation of more efficient, reliable, and sustainable bearing solutions that propel industries forward.

In summary, the future of spherical roller bearings with steel cage technology is bright, with emerging trends and innovations poised to revolutionize the way these bearings are designed, manufactured, and utilized across various industrial sectors. By staying at the forefront of technological advancements and prioritizing research and development, stakeholders can optimize performance, enhance efficiency, and ensure the continued success of steel cage bearings in the years to come.



Spherical Roller Bearings/Steel Cage

6 Conclusion

In conclusion, this article has delved into the realm of optimizing performance through the utilization of Spherical Roller Bearings with Steel Cage technology. We have explored various aspects related to the design, application, and future trends of these critical components in industrial machinery.

Summary of Key Points

Throughout the discussion, we have highlighted the importance of understanding the fundamentals of Spherical Roller Bearings and the role that steel cage technology plays in enhancing their performance. We examined the benefits of steel cages, such as improved durability, strength, and performance, which are essential for demanding operating conditions across different industries.

Significance of Spherical Roller Bearings with Steel Cage

Spherical Roller Bearings with Steel Cage technology offer unmatched reliability and efficiency, making them indispensable in a wide range of applications, including automotive, industrial, and aerospace sectors. By optimizing performance, these bearings contribute to increased productivity, reduced downtime, and overall cost savings for businesses.

Future Outlook and Potential

Looking ahead, the future of Steel Cage technology in Spherical Roller Bearings appears promising. With ongoing research and development efforts, we anticipate further advancements in cage design, material science, and lubrication systems, leading to even greater performance enhancements and efficiencies.

Closing Remarks

In conclusion, Spherical Roller Bearings with Steel Cage technology represent a cornerstone of modern engineering, enabling machines to operate at peak performance levels. As industries continue to evolve and demand higher standards, the significance of these bearings in optimizing performance cannot be overstated. By embracing innovation and investing in technological advancements, we can unlock new possibilities and propel industrial progress into the future.

7 FAQs: Common Questions About Spherical Roller Bearings/Steel Cage

1. What are Spherical Roller Bearings with Steel Cage?

Spherical roller bearings with steel cage refer to a type of rolling-element bearing that utilizes a steel cage to separate and guide the rolling elements (usually spherical rollers) within the bearing. The steel cage serves as a robust and durable framework, providing support and maintaining proper alignment of the rollers, thereby optimizing the performance and longevity of the bearing.

2. How Can I Ensure Optimal Performance of Spherical Roller Bearings with Steel Cage?

To maximize the performance and longevity of spherical roller bearings with steel cage, it is essential to follow proper installation, maintenance, and lubrication practices recommended by the manufacturer. Regular inspection and monitoring of bearing condition, temperature, and vibration levels are also critical for detecting potential issues early and preventing premature failure.

3. How Does Steel Cage Technology Improve Bearing Performance?

Steel cage technology enhances bearing performance by providing reliable guidance and spacing of the rolling elements, thereby minimizing friction, reducing heat generation, and extending bearing service life. The rigid and lightweight nature of steel cages ensures smooth operation and optimal load distribution, resulting in improved efficiency and reliability of spherical roller bearings.

4. What Industries Benefit from Spherical Roller Bearings with Steel Cage?

Spherical roller bearings with steel cage find widespread applications across various industries, including automotive, aerospace, construction, mining, and manufacturing. These bearings are commonly used in heavy machinery, conveyor systems, gearboxes, wind turbines, and other equipment where high load capacity, shock resistance, and reliable performance are essential.

5. Are There Different Types of Steel Cage Designs for Spherical Roller Bearings?

Yes, manufacturers offer a range of steel cage designs to suit different application requirements and operating conditions. Some common variations include pressed steel cages, machined brass cages, and stamped steel cages, each offering distinct advantages in terms of strength, weight, and cost-effectiveness.

In conclusion, Spherical Roller Bearings with Steel Cage offer numerous benefits and are widely used across various industries. Understanding their design, advantages, applications, and maintenance practices is essential for ensuring optimal performance and reliability in industrial machinery and equipment.